

NEMA14-01

Bipolar Stepper Motor

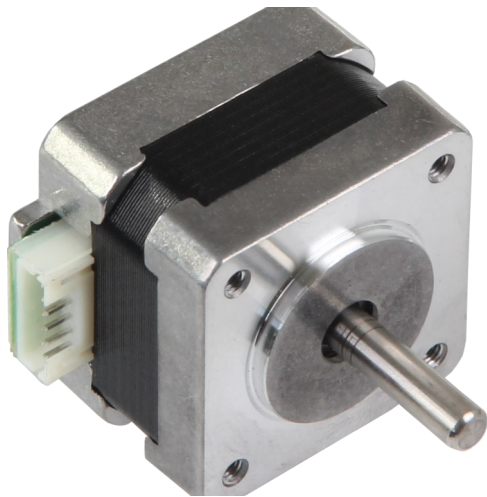

This small sized stepper motor is optimal for smaller tasks in automation, CNC (e. g. laser engraver, 3d printer, etc), or robotic. The small design and the little weight predestine this stepper motor for projects with limited space and / or limited weight capacity.

KEY FEATURES

Shaft dimensions	Ø 5 x 16 mm (single shaft)
Specification	35SHD0001-20
Connection	6 pole socket S6B-PH-K (JST compatible), 4 Pins used
Steps per Revolution	200
Dimensions	35 x 35 x 29 mm
Items delivered	NEMA14-01 Stepper Motor

PERFORMANCE CHARACTERISTICS

Holding torque	0.1 Nm
Step angle	1.8 °
Rated voltage	8 V
Rated current	0.4 A
Amount of Phases	2
Phase resistance	20 Ω
Phase inductivity	20 mH
Isolation resistance	min. 100MΩ at 500 V
Isolation class	B (130°C)
Rotational inertia	12 g·cm ²
Detent torque	0.008 Nm
Operating temperature	-10°C - 50°C

FURTHER DETAILS

Article No.	NEMA14-01
EAN	4250236818740
Customs Tariff No.	8501109990

DRAWING

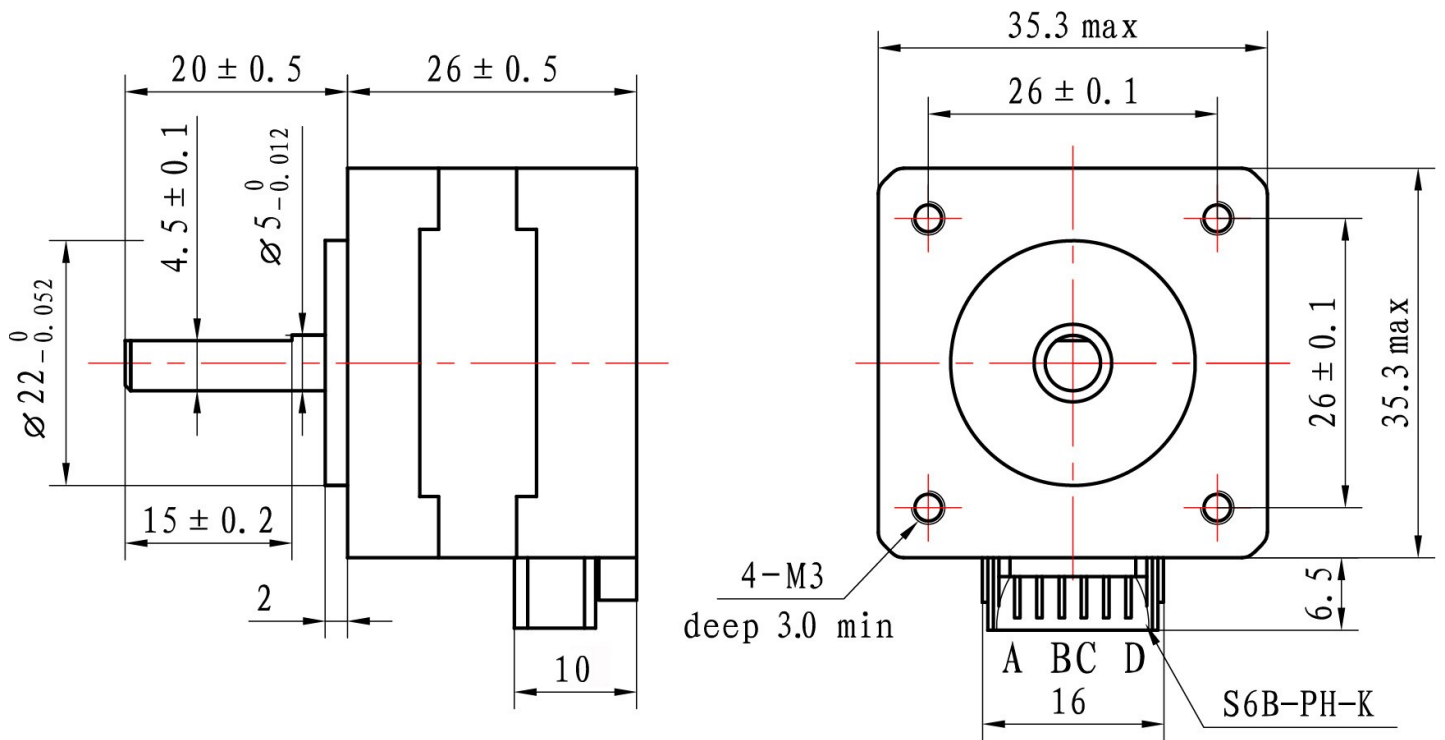

WIRING

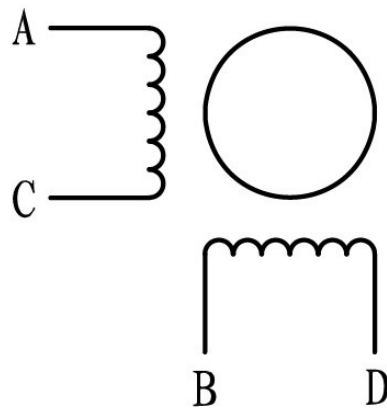

TORQUE DIAGRAM

2H-422 DRIVER SETTINGS

Voltage 23,88 V

max. current 1,0 A

T(mN.m)

180

162

144

126

108

90

72

54

36

18

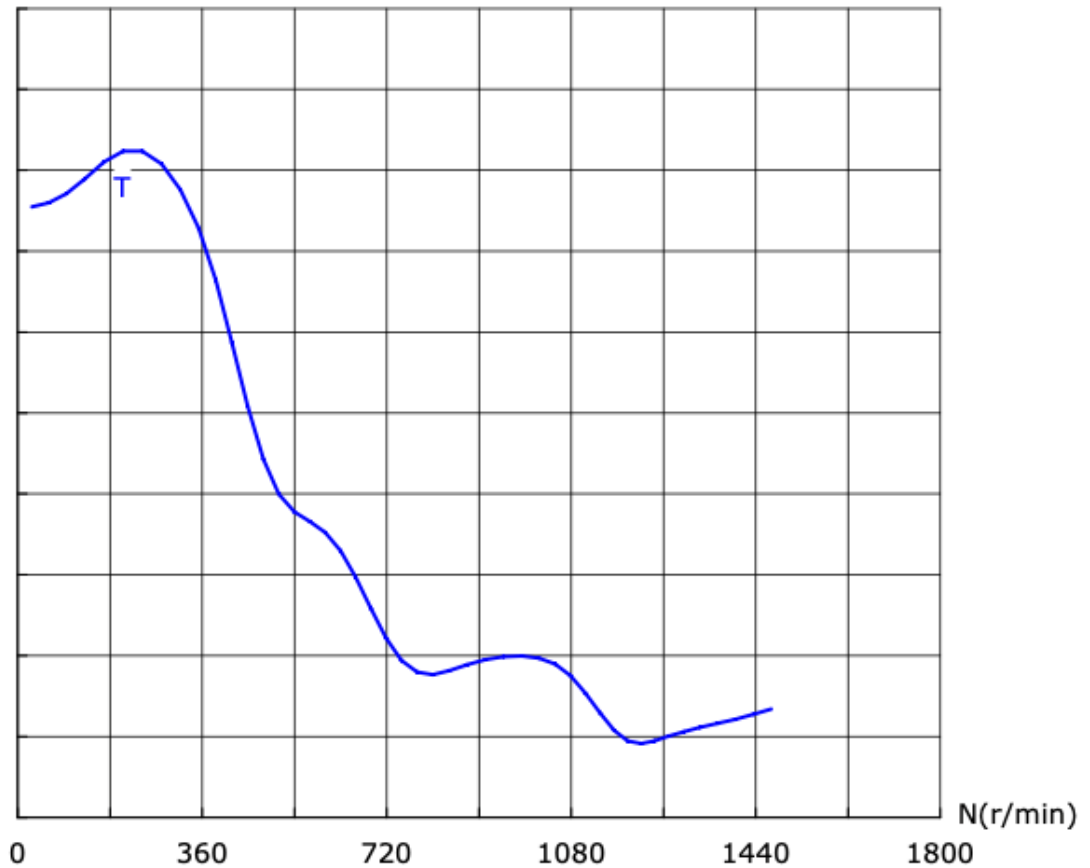

MAX. EFFICIENCY

Efficiency 75,1 %

Torque 35,5 mNm

Current 0,239 A

Speed 1017 min⁻¹

Output power 3,771 W

MAX. TORQUE

Torque 148,3 mNm

Current 0,578 A

Speed 243 min⁻¹

Output power 3,755 W

MAX. POWER

Torque 131,1 mNm

Current 0,530 A

Speed 353 min⁻¹

Output power 4,726 W

Published: 24.11.2025