

5-WAY NAVIGATION SWITCH

Navigation switch with 5 directions and two additional buttons

1. GENERAL INFORMATION

Dear Customer,
thank you for choosing our product. In the following, we will show you what to consider during commissioning and use.

Should you encounter any unexpected problems during use, please feel free to contact us.

2. BASICS & CONNECTION OF THE MODULE

The navigation switch has a total of 5 directions (left, right, up, down, press) and is equipped with two additional buttons. All contacts are closed via a common ground pin.

The module can be connected as follows:

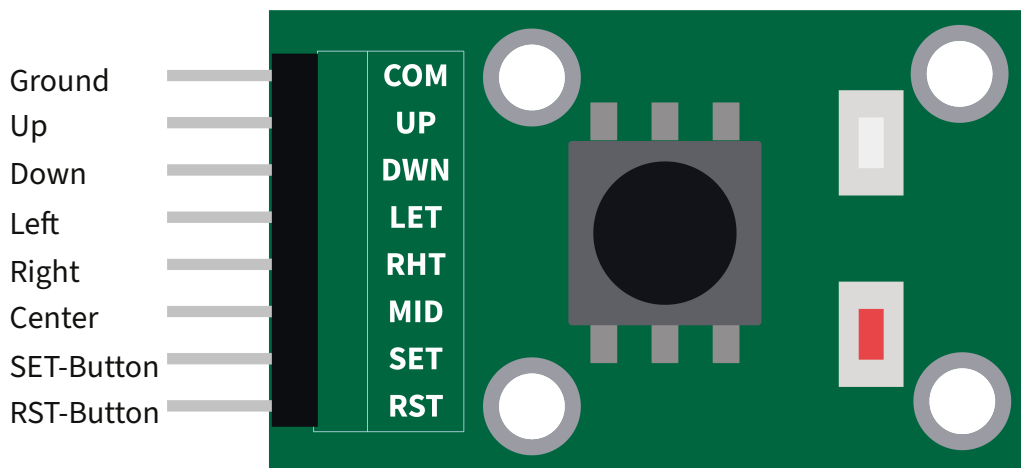

3. RASPBERRY PI EXAMPLE



This guide was written under Raspberry Pi OS Bookworm for the Raspberry Pi 4 and 5. It has not been checked with newer operating systems or hardware.

First connect the module to your Raspberry Pi:

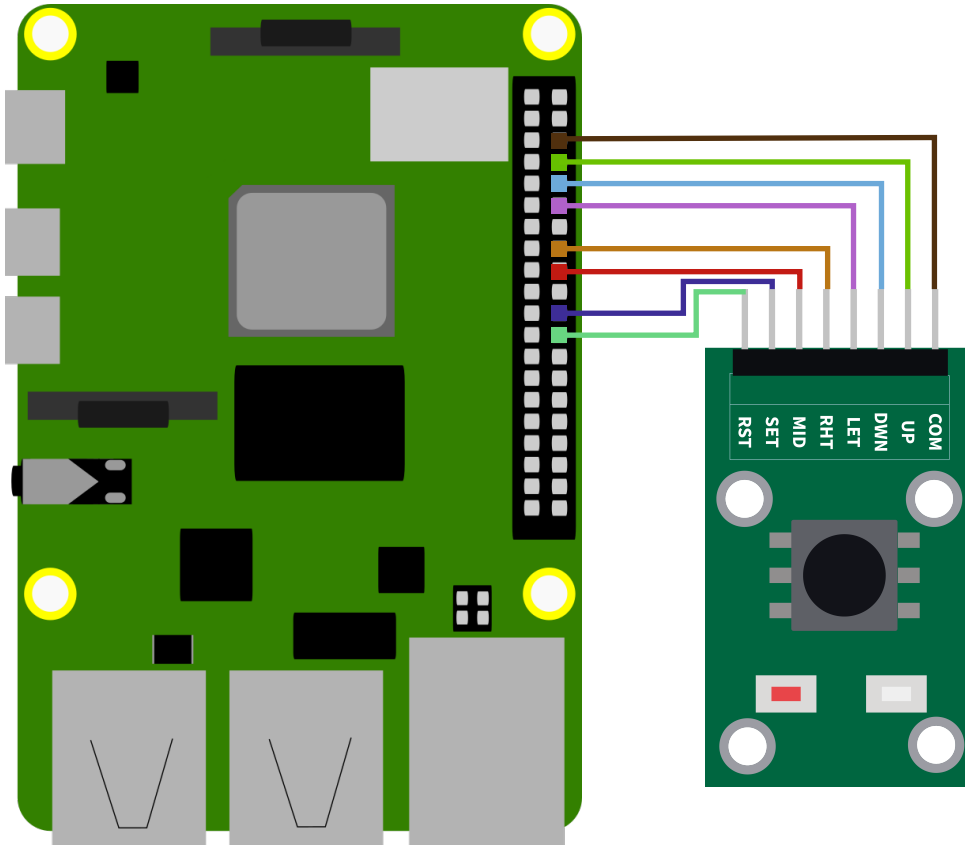

RASPBERRY PI	5-WAY SWITCH
COM	GND
GPIO14	UP
GPIO15	DWN
GPIO18	LET
GPIO23	RHT
GPIO24	MID
GPIO25	SET
GPIO8	RST

Now transfer the following code example to your Raspberry Pi:

```
from gpiozero import Button
import time

# Define buttons with their BCM pin numbers and enable internal pull-up
up_button = Button(14, pull_up=True)
down_button = Button(15, pull_up=True)
left_button = Button(18, pull_up=True)
right_button = Button(23, pull_up=True)
center_button = Button(24, pull_up=True)
set_button = Button(25, pull_up=True)
reset_button = Button(8, pull_up=True)

while True:
    if not up_button.is_pressed:
        print("Up")
    if not down_button.is_pressed:
        print("Down")
    if not left_button.is_pressed:
        print("Left")
    if not right_button.is_pressed:
        print("Right")
    if not center_button.is_pressed:
        print("Center pressed")
    if not set_button.is_pressed:
        print("SET Button pressed")
    if not reset_button.is_pressed:
        print("RST Button pressed")

    time.sleep(0.5)
```

Alternatively, you can download it using the following command:

```
wget https://joy-it.net/files/files/Produkte/COM-5WS/COM-5WS-RPi.zip
unzip COM-5WS-RPi.zip
```

Now run the sample program with the following command:

```
python3 COM-5WS-RPi.py
```

4. ARDUINO EXAMPLE

First connect the module to your Arduino:

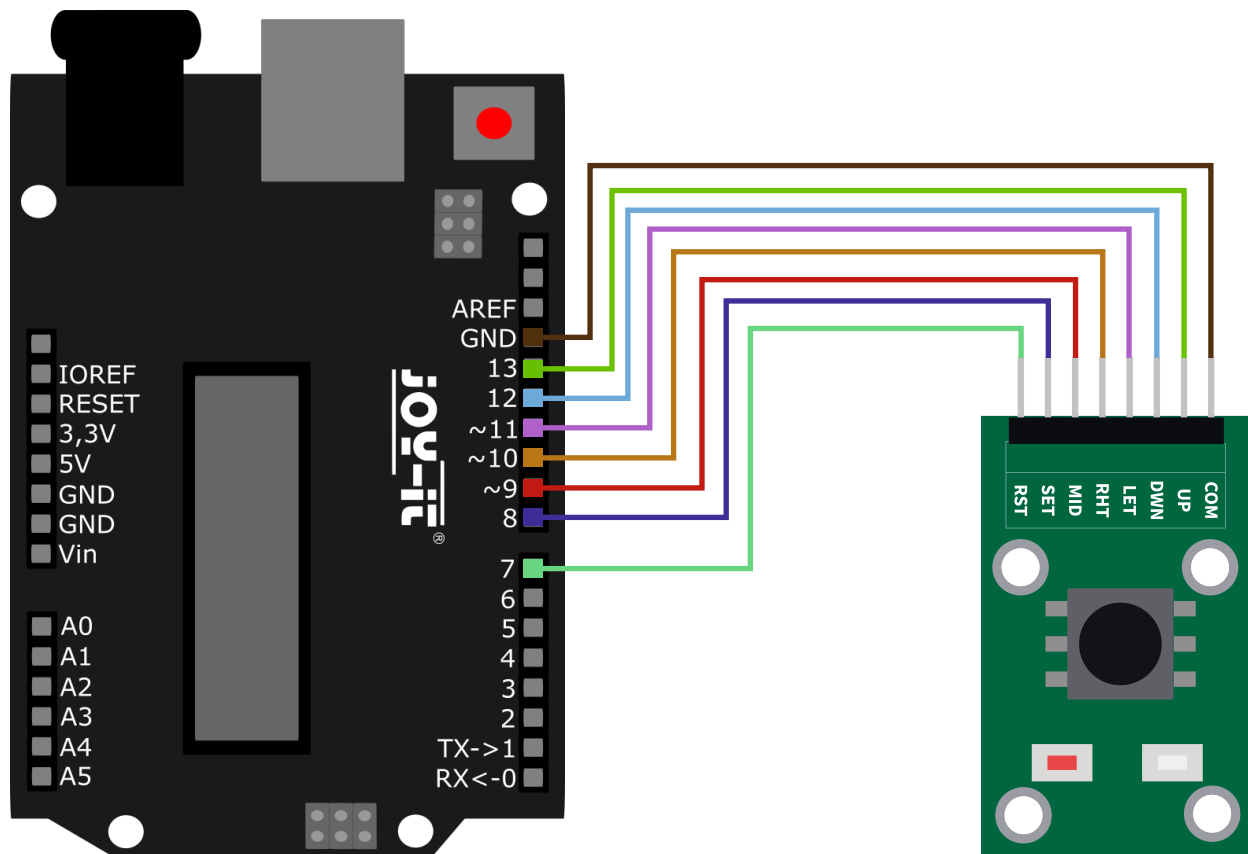

ARDUINO

5-WAY SWITCH

GND

GND

D13

UP

D12

DWN

D11

LET

D10

RHT

D9

MID

D8

SET

D7

RST

Now transfer the following code example to your Arduino. Alternatively you can download it [here](#).

```
int upPin = 13;
int dwnPin = 12;
int letPin = 11;
int rhtPin = 10;
int midPin = 9;
int setPin = 8;
int rstPin = 7;

void setup() {
  Serial.begin(9600);
  pinMode(upPin, INPUT_PULLUP);
  pinMode(dwnPin, INPUT_PULLUP);
  pinMode(letPin, INPUT_PULLUP);
  pinMode(rhtPin, INPUT_PULLUP);
  pinMode(midPin, INPUT_PULLUP);
  pinMode(setPin, INPUT_PULLUP);
  pinMode(rstPin, INPUT_PULLUP);
}

void loop() {
  if(digitalRead(upPin) == LOW){
    Serial.println("Up");
  }
  if(digitalRead(dwnPin) == LOW){
    Serial.println("Down");
  }
  if(digitalRead(letPin) == LOW){
    Serial.println("Left");
  }
  if(digitalRead(rhtPin) == LOW){
    Serial.println("Right");
  }
  if(digitalRead(midPin) == LOW){
    Serial.println("Center Button pressed");
  }
  if(digitalRead(setPin) == LOW){
    Serial.println("SET Button pressed");
  }
  if(digitalRead(rstPin) == LOW){
    Serial.println("RST Button pressed");
  }
  delay(500);
}
```

5. INFORMATION & TAKE-BACK OBLIGATIONS

Our information and take-back obligations under the Electrical and Electronic Equipment Act (ElektroG)



Symbol on electrical and electronic equipment:

This crossed-out trash can means that electrical and electronic equipment does **not** belong in the household trash. You must hand in the old equipment at a collection point. Before dropping off, you must separate used batteries and accumulators that are not enclosed in the old device from the old device.

Return options:

As an end user, when you purchase a new appliance, you can return your old appliance (which performs essentially the same function as the new one purchased from us) for disposal free of charge. Small appliances with no external dimensions larger than 25 cm can be returned in normal household quantities, regardless of the purchase of a new appliance.

Possibility return to our company location during opening hours:

SIMAC Electronics GmbH, Pascalstr. 8, D-47506 Neukirchen-Vluyn

Possibility return in your area:

We will send you a parcel stamp with which you can return the device to us free of charge. To do this, please contact us by e-mail at service@joy-it.net or by phone.

Packaging information:

Please pack your old device securely for transport. If you do not have suitable packaging material or do not wish to use your own, please contact us and we will send you suitable packaging.

6. SUPPORT

We are also there for you after the purchase. If you have any questions or problems arise, we are also available by e-mail, telephone and ticket support system.

E-Mail: service@joy-it.net

Phone: +49 (0)2845 9360 – 50

For more information visit our website:

www.joy-it.net